

# MMA Technical Standards Board/ AMEI MIDI Committee

## Confirmation of Approval for MIDI Standard

(CA-033) MIDI 1.0 Electrical Specification Update [2014]

|  |                                       |                    |
|--|---------------------------------------|--------------------|
| Originated by: <u>MMA</u>  | Reference MMA Item #: <u>202</u>      | TSBB #: <u>37</u>  |
| Issue Date: <u>Aug 1 2014</u>  | MMA Approval Date: <u>Jan 20 2014</u> | Revised:           |
| Related item(s): <u>MIDI 1.0 Detailed Specification (Document Version 4.2)</u> |                                       |                    |
| Agreed by MMA: _____   | <u>President/CEO</u>                  | <u>Feb 10 2015</u> |
| <i>Signature</i>   | <i>Title</i>                          | <i>Date</i>        |
| Agreed by AMEI: _____  | <u>Chairman</u>                       | <u>Mar 19 2015</u> |
| <i>Signature</i>   | <i>Title</i>                          | <i>Date</i>        |

**Primary Author:** Tom Savell (Creative Labs & Microsoft)

### **Abstract:**

This document updates the MIDI 1.0 Electrical Specification to include 3.3-volt signaling and optional RF grounding. This document replaces the *Hardware* section of the *MIDI 1.0 Detailed Specification (Document Version 4.2)*, which is included in the MMA publication "The Complete MIDI 1.0 Detailed Specification".

### **Background:**

When the MIDI 1.0 Specification was written, 5-volt signaling was the industry standard for electronic circuits. The standard MIDI transmitter circuit in the Specification requires the use of 5 volts. However, today's industry standard is 3.3 volts, so there is a significant advantage in cost and complexity of newly-developed devices to adapt the MIDI transmitter circuit for 3.3-volt signaling.

In addition, the Specification requires that pin 2 of the MIDI In jack not be connected to ground to avoid ground loops. The MIDI cable shield thus depends on the ground from Pin 2 of the MIDI Out or MIDI Thru jack. This works well for audio frequency signals. However, it is less effective for high frequency (e.g. RF) interference. An optional solution to improve RF performance is to connect pin 2 of the MIDI In jack to the local device ground through a small-valued capacitor. This maintains the ground-loop isolation at audio frequencies while providing a low-impedance path to ground at radio frequencies.

Further, compliance with Electro-Magnetic Interference / Electro-Magnetic Compatibility (EMI/EMC) regulations may require filtering of RF interference on signal pins of the MIDI jacks as well. This update to the Specification adds optional ferrite bead RF filters to the signal pins. The update also adds optional grounding provisions for the grounding shield connectors on the MIDI jacks.

Please refer to The Complete MIDI 1.0 Detailed Specification for more information on the subject matter.

### **Details:**

See the attached document.

## HARDWARE

The hardware MIDI interface operates at 31.25 (+/- 1%) Kbaud, asynchronous, with a start bit, 8 data bits (D0 to D7), and a stop bit. This makes a total of 10 bits for a period of 320 microseconds per serial byte. The start bit is a logical 0 (current ON) and the stop bit is a logical 1 (current OFF). Bytes are sent LSB first.

### MIDI Circuit:

The MIDI circuit is a 5mA current loop; logical 0 is current ON. One output shall drive one and only one input. To avoid ground loops, and subsequent data errors, the transmitter circuitry and receiver circuitry are internally separated by an opto-isolator (a light emitting diode and a photo sensor which share a single, sealed package). Sharp PC-900V and HP 6N138 opto-isolators have been found acceptable. Other high-speed opto-isolators may be satisfactory. The receiver must require less than 5 mA to turn on. Rise and fall times should be less than 2 microseconds.

In addition to a MIDI In and MIDI Out circuit, a MIDI Thru output may be provided if needed, which provides a direct copy of data received at the MIDI In jack. When MIDI Thru information is obtained from a MIDI In signal, transmission may occasionally be performed incorrectly due to signal degradation of the rising and falling edges of the data signal caused by the response time of the opto-isolator. These timing errors will tend to add up in the wrong direction as more devices are chained between MIDI Thru and MIDI In jacks. The result is that, regardless of circuit quality, there is a limit to the number of devices that can be chained (series connected) in this fashion. For long chain lengths (more than three instruments), higher speed opto-isolators should help to avoid additive rise- and fall-time errors that can affect pulse-width duty-cycle. The MIDI Thru circuit is shown in the same schematic as the MIDI In circuit (Figure 2).

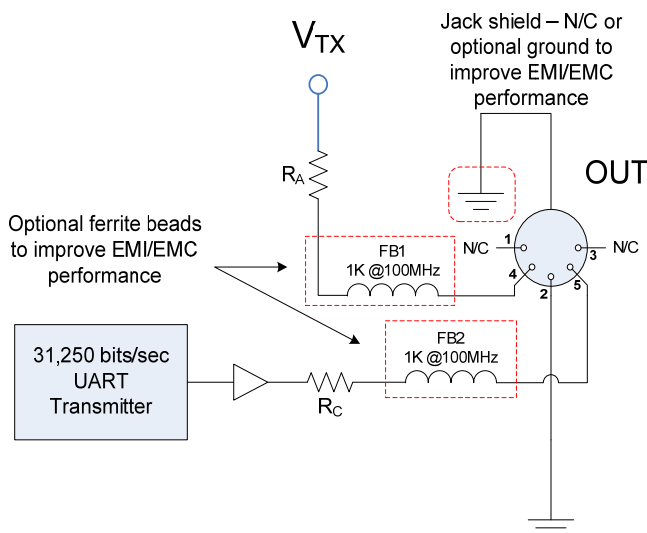

Pin 2 must be tied to ground on the MIDI transmitter only.

The buffer between the UART transmitter and  $R_C$  is optional and system-dependent.

The UART is configured with 8 data bits, no parity, and 1 stop bit, or 8-N-1.

The resistor values depend on the transmission signaling voltage,  $V_{TX}$ , as detailed below.

The optional ferrite beads are 1k-ohm at 100MHz such as MMZ1608Y102BT or similar.

|          |                       |                      |
|----------|-----------------------|----------------------|
| $V_{TX}$ | +5V $\pm$ 10%         | +3.3V $\pm$ 5%       |
| $R_A$    | 220 $\Omega$ 5% 0.25W | 33 $\Omega$ 5% 0.5W  |
| $R_C$    | 220 $\Omega$ 5% 0.25W | 10 $\Omega$ 5% 0.25W |

**Figure 1 – MIDI OUT Circuit**

The buffer shown in the MIDI Out circuit driving  $R_C$  is optional and system-dependent, and if present, may be implemented as an IC gate or transistor or a combination.

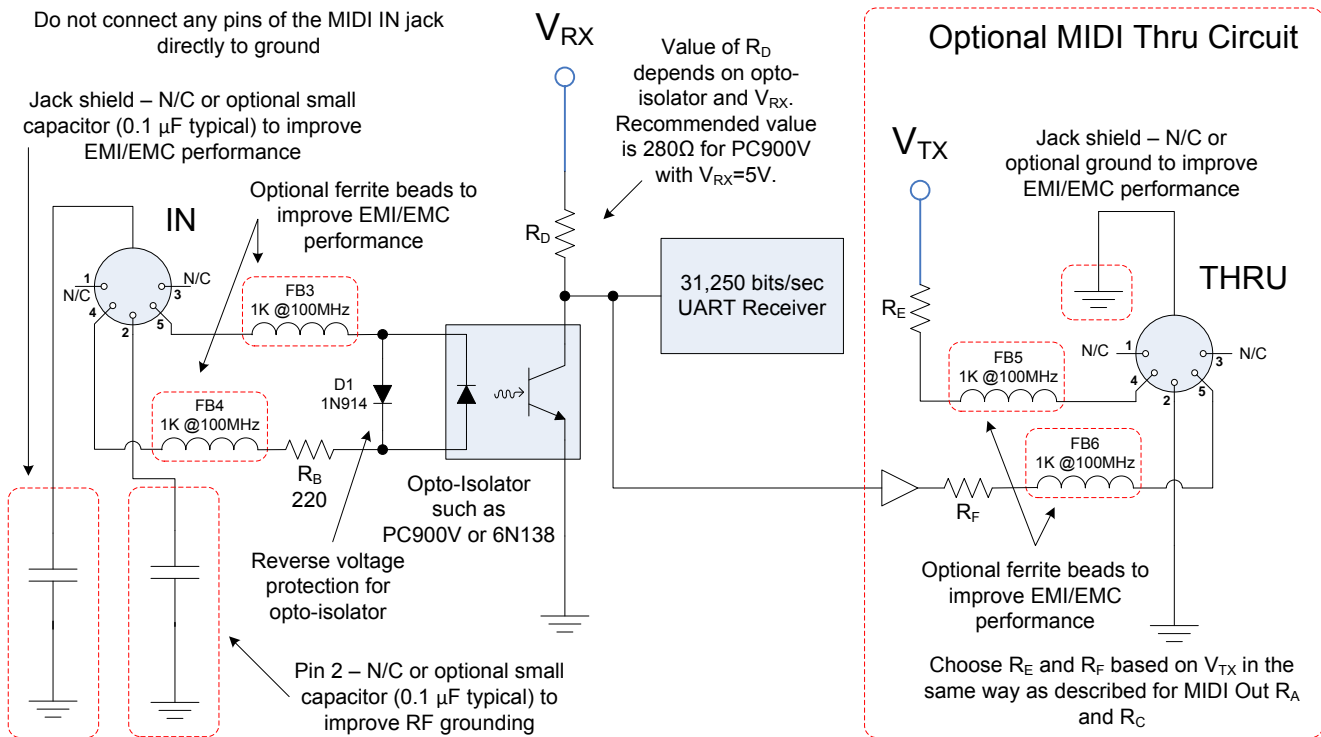

Figure 2 – MIDI IN and THRU circuit

**MIDI Device Connectors:**

The MIDI Out, In, and optional Thru jacks shall be DIN 5-pin (180 degree) female panel-mount receptacles. An example is the SWITCHCRAFT 57PC5F. The connectors shall be labeled “MIDI OUT”, “MIDI IN”, and “MIDI THRU”. Note that pins 1 and 3 are not used, and should be left unconnected in the receiver and transmitter.

Pin 2 of the MIDI In connector shall not have any DC path to the receiver’s ground. However, a connection through a small capacitor (0.1 $\mu$ F typical) to ground is optional for improved high-frequency (RF) shielding.

The shield connector of the MIDI In jack shall not have any DC path to the receiver’s ground. However, a connection through a small capacitor (0.1 $\mu$ F typical) to ground is optional for improved EMI/EMC performance.

The shield connector of the MIDI Out and MIDI Thru jacks may be unconnected (N/C) or connected to ground for improved EMI/EMC performance.

**MIDI Cable:**

The MIDI cable shall have a maximum length of fifty feet (15 meters), and shall be terminated on each end by a corresponding 5-pin DIN male plug such as the SWITCHCRAFT 05GM5M. The cable shall be shielded twisted pair, with the shield connected only to pin 2 at both ends, as illustrated in Figure 3, below.

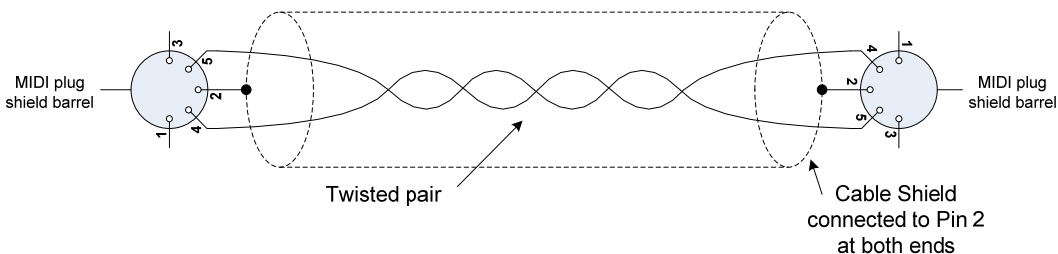

**Figure 3 – MIDI Cable**

Do not connect the MIDI cable shield to the shield barrel of the MIDI plug.  
Cable connection to pins 1 and 3 is not required by this specification, but may be present.

### **Low-Voltage Signaling Details:**

The MIDI current loop can run at low-voltage (3.3V) signal levels. The MIDI output circuit is the only affected component for Low-Voltage Signaling. It requires changing the output resistors from 220Ω to 33Ω and 10Ω (±5%) and changing the voltage from +5V to +3.3V (±5%).

The schematic diagram in Figure 1, above, supports either +5V or +3.3V signaling.

### **Low-Voltage Signaling Technical Notes:**

The standard MIDI circuit is a current-loop that drives an opto-isolator located in the receiver returning the current to the transmitter. From the viewpoint of the transmitter, the opto-isolator is electrically identical to an LED in series with a 220Ω resistor. The opto-isolators found in some MIDI devices have an LED maximum forward voltage drop of 1.9V and can require up to 5mA typical<sup>1</sup> current drive for normal operation. The actual required current is opto-isolator dependent. For example, the PC900V has a worst-case forward current requirement of 4mA when  $R_D = 280\Omega$  (see Figure 2) and  $V_{RX} = 5V$ .

In order to supply 5mA to this circuit, the transmitter voltage must satisfy the following relationship:

$$V_{TX} \geq V_{RXDROD} = .005 * 220 + 1.9$$

This reduces to:

$$V_{TX} \geq V_{RXDROD} = 3.0V$$

It is required to have short-circuit current-limiting on the MIDI Output as well, which is achieved by series resistors on each of the two output pins. The series resistors are also subject to the IR voltage drop introduced by the 5 mA current, thus increasing the minimum transmitter voltage. The logical choice is +3.3V as a minimum transmitter voltage. The series resistor values should satisfy the following relationship:

$$(R_A + R_C) = (V_{TX} - V_{RXDROD}) / .005$$

<sup>1</sup> The original 5V MIDI circuit specified 5mA, which can be derived from the typical total series resistance of 660Ω (3\*220Ω), typical signaling voltage of +5V and the 1.7V maximum forward drop of a 6N138 opto-isolator.

Substituting +3.135V (95% of +3.3V) for  $V_{TX}$  and solving for  $(R_A + R_C)$ , this reduces to:

$$(R_A + R_C) = 27\Omega$$

The recommended values of  $33\Omega$  and  $10\Omega$  for  $R_A$  and  $R_C$  produce a total resistance of  $43\Omega$ , which reduces the worst-case current to 4.472 mA, assuming a -5% power supply, +5% resistors, and a forward drop of 1.9V. It is not clear, however, that 1.9V can be achieved with only 4.472 mA drive, as the maximum forward drop occurs at the highest current. If the forward drop decreases, the current through the resistors increases.

With a nominal supply voltage of exactly 3.3V, exact-valued resistors, and a typical forward voltage drop of 1.4V (for 6N138 at 25°C and approx. 7-8 mA) the circuit obtains forward current of approx. 7.2 mA.

Using +5% maximum voltage and -5% minimum resistance value, the maximum short-circuit current (to ground) through  $R_A$  will be:

$$I_{MAXSHORT} = 3.465 / 31.35$$

This reduces to:

$$I_{MAXSHORT} = 0.111A$$

The maximum short-circuit power dissipation will be:

$$P_{MAXSHORT} = 0.383W$$

This requires using a 0.5W resistor or additional current-limiting circuitry. The  $R_A$  resistor is pulling straight up to a 3.3V power supply, so the 0.5W rating is necessary. It is, of course, acceptable to use parallel resistors to achieve a higher power rating. For example, one could use four 0.125W 130Ω resistors in parallel, producing an equivalent resistance of  $32.5\Omega$  and power rating of 0.5W.

It is assumed that the digital buffer driving  $R_C$  in 3.3V designs is open collector or open drain, which allows a smaller 0.25W resistor to be used with adequate protection in the event of a MIDI cable short-circuit. Care must be taken when using digital buffers in 3.3V designs to not exceed the buffer's maximum short-circuit current in the event of a MIDI cable short-circuit.

### **Low-Voltage Signaling Interoperability Issues:**

The low-voltage signaling circuit is compatible with all legacy MIDI 1.0 receivers that strictly follow the specification. Products that deviate from or attempt to extend the specification may not be 100% compatible.<sup>2</sup>

Possibly incompatible circuit designs include non-opto-isolated receivers and devices that draw power from Pin 4 through the  $220\Omega$  resistor ( $R_A$  or  $R_E$ ) to +5V.

---

<sup>2</sup> The MMA does not maintain a list of strictly compatible or potentially incompatible MIDI receiver products.

A non-opto-isolated receiver is likely to be voltage-sensitive and the lower signaling voltage may not adequately drive the receiver above its input high signaling voltage. This type of receiver is also a possible source of ground loops, since the lack of isolation requires tying the grounds together.

Devices that draw power from Pin 4 may fail to operate when pin 4 is tied to +3.3V instead of +5V, as the power supply circuit may depend on a minimum voltage available that is greater than that supplied by the +3.3V transmitter. This type of receiver is also a possible source of ground loops, since the power supply must return to the ground of the transmitter. If the receiver's ground is also tied to the ground of another device, a ground loop may be formed.

### **(Optional) RF Grounding Details:**

The MIDI input circuit is specified to operate with no connection to ground, in order to avoid ground loops. This is good for audio-frequency signals. However, the cable inductance raises the impedance at high (RF) frequencies making the transmitter ground less effective at longer cable lengths. One solution to this is to connect Pin 2 of the MIDI In jack to ground through a small capacitor. The small capacitor provides a low-impedance path to ground for high (RF) frequencies at the MIDI Receiver side while maintaining immunity to audio-frequency ground loops. A capacitor value of 0.1 $\mu$ F is optionally recommended, which results in an impedance of 0.16 $\Omega$ <sup>3</sup> at 10 MHz; practically a dead short. At 20 kHz the impedance is 79.6 $\Omega$ , and at 60 Hz the impedance is 26.5k $\Omega$ .

The schematic in Figure 2 (above) illustrates the use of the optional RF grounding capacitor.

### **(Optional) Improved EMI/EMC Performance Details:**

The optional ferrite beads FB1-6 shown in Figures 1-2 attenuate RF interference by presenting an impedance of 1k $\Omega$  at 100MHz while having a DC resistance of near zero. Although an example component (MMZ1608Y102BT) is designated, different components may be substituted to tune the impedance characteristic to the specific product design. The ferrite beads are optional and are not required for proper MIDI functionality. They may be omitted if the product does not need them to comply with EMC regulations.

If present, the ferrite beads should be placed as close to the jacks as possible. The schematics in Figure 1 and Figure 2 (above) illustrate the use of the optional ferrite beads.

The MIDI 1.0 Detailed Specification (Document Version 4.2) states that “the grounding shield connector on the MIDI jacks should not be connected to any circuit or chassis ground.” This was mandated to avoid ground loops between devices when an improperly wired MIDI cable was used (an improperly wired MIDI cable may have a connection to one or more of the shield barrels of its MIDI plugs).

However, to improve EMI/EMC performance, it is now permitted, as an option, to connect the grounding shield connectors on MIDI Out and MIDI Thru jacks to ground. It is also permitted, as an option, to connect the grounding shield connector of a MIDI In jack to a small capacitor to ground (0.1 $\mu$ F typical), in order to avoid a ground loop when an improperly wired MIDI cable is connected. But it is still not permitted to connect the grounding shield connector of a MIDI in jack directly to ground.

---

<sup>3</sup> To be mathematically correct, the capacitor impedance is imaginary and negative, so the textbook impedance would be  $-0.16j\Omega$ . In the interest of simplicity, the complex number representation is not used.